

R 12D

Feeders for mailing,
printing and packaging

R-12D DEMAND FEEDER

Our R-12D and the wide format R-20D friction feeders are the solution to your demand AND continuous feed applications!

Utilizing proven Straight Shooter innovations like Buckle Separation™ and repositionable feed belts and separators, the R-12D now offers a simple, cost effective solution for packaging applications.

The R-12D's unique adjustable PIVOT angle acceleration table allows you to deliver documents to your production machinery at the optimum angle, no matter what the application! This enhances productivity while minimizing waste.

WE'LL GIVE IT TO YOU STRAIGHT... LITERALLY!

Our complete paper guides and repositionable belt ideas are carried through in the R-12D acceleration table, giving you unmatched versatility and control.

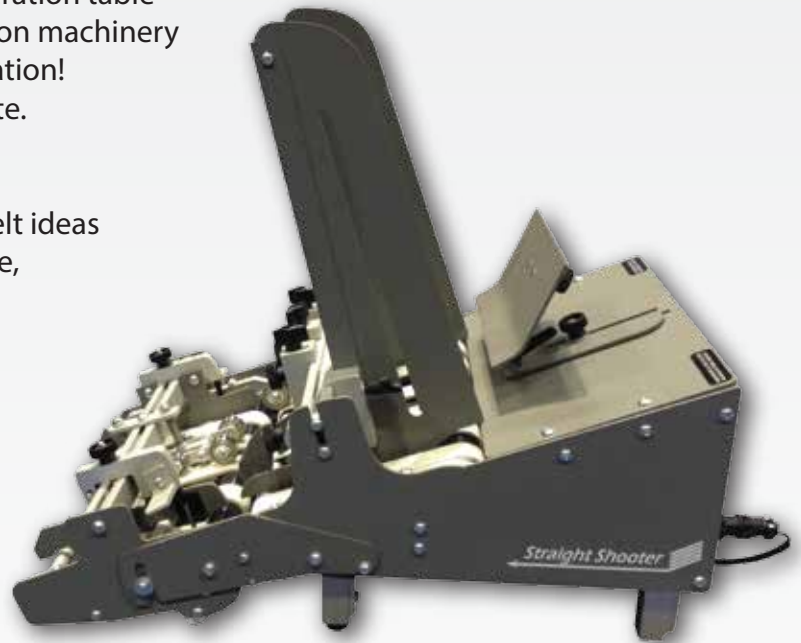

R-12D AND R-20D FEEDERS ARE GREAT FOR FEEDING INTO:

- * **COLLATORS**
- * **SHRINK WRAP EQUIPMENT**
- * **PLOW FOLDERS**
- * **INK JET EQUIPMENT**
- * **TABBING MACHINES**
- * **BINDERY EQUIPMENT**

STRAIGHT SHOOTER EQUIPMENT COMPANY \ 580 AXMINISTER DRIVE, FENTON, MO 63026
PHONE (607) 334-6811 FAX (607) 336-2181 TOLL FREE (800) 785-4177 WWW.FEEDSTRAIGHT.COM

Patented Buckle Separation Technology™ • Patented Acceleration Table Technology™ • Additional Patent Pending © Straight Shooter Equipment Company

VERSATILITY!

Simple angle adjustment on the acceleration table allows you to customize the R-12D for any application.

Set the table flat for ink jetting or tabbing and downward for collators and bindery equipment



The R-12D offers all the features Straight Shooter has become known for:

- * Complete paper guides for straight delivery of your documents
- * Repositionable belts – let you put the friction where YOU want it!
- * Buckle separation™ for smoother separation without the jams!
- * Multiple, independently adjustable separators for greater versatility
- * Quick, easy belt changes reduce downtime and save you money!
- * Acceleration table creates gaps between documents for accurate photo eye detection AND delivers documents smoother and faster!

SPECIFICATIONS

Media Handling:

Width: 3" minimum up to 12" maximum
(20" on R-20D)

Length: 2" minimum up to 17" maximum

Thickness: Single sheet up to 3/8" thick

Speeds: Up to 40,000 postcards per hour

Power:

120 vac, 5 amp standard, (240 optional)

Dimensions R-12D: 17" wide x 26" long

Dimensions R-20D: 23" wide x 26" long

Weight: 65 lbs-boxed (12") 80 lbs – boxed (20")

STRAIGHT SHOOTER EQUIPMENT COMPANY \ 580 AXMINISTER DRIVE, FENTON, MO 63026
PHONE (607) 334-6811 FAX (607) 336-2181 TOLL FREE (800) 785-4177 WWW.FEEDSTRAIGHT.COM